

Raex

M701-E

electronic curtain track motor

IDEAL FOR HEAVYWEIGHT CURTAINS - LOW VOLTAGE ACTIVATION

By *windoware™*

45 Disraeli Street, Addington, Christchurch, New Zealand Phone 03 366 9810 Fax 03 366 5707
Email: mcprnz@windoware.co.nz

website: www.windoware.co.nz



M701-E

SYSTEM SPECIFICATIONS

ATTENTION:

- 1) Please read these specifications and instructions carefully prior to any installation being carried out.
- 2) It is recommended that the installation of the 701-E be carried out by a professional.
- 3) DO NOT install the 701-E System outside or in high humidity situations. Avoid direct sunlight.
- 4) DO NOT hit any of the components. NEVER attempt to repair any components.
- 5) NEVER add lubricants to the motor, as all the components in this system are pre-lubricated.



Quiet - Stable - Strong...



Installation Instructions

1) SPECIFICATION DETAILS

This system is driven by AC Synchronal drive. It is compatible with straight and curve Raex tracks and widely used in all kinds of drapery and canopies. With strong load capacity thermal protection and inbuilt radio receiver makes this system very convenient to install and use.

To assist with home automation, a 4 pin port, provided on the outer case of the motor, allows for external 'low voltage dry contact switching', providing both directional and stop functions.

This system is suitable for home, hotel, hospital and community hall situations.

TYPE	VOLTAGE (V)	FREQUENCY (Hz)	POWER (W)	TORQUE (Nm)	SPEED (rpm)	INSULATION CLASS	PROTECTION INDEX
M700-2/124-E	230V	50Hz	120W	2	124	I. cl. F	IP44



8) SINGLE CONNECTION DIAGRAM

PLEASE NOTE THE FOLLOWING:

- 1) External switching can be achieved through the 4 pin port on the motor.
- 2) 4P4C telephone cable and plug are used for external dry contact switching.
- 3) When the telephone cable connects with the plug, the colour of the cable cores must be ranked as indicated on the drawing diagram below.

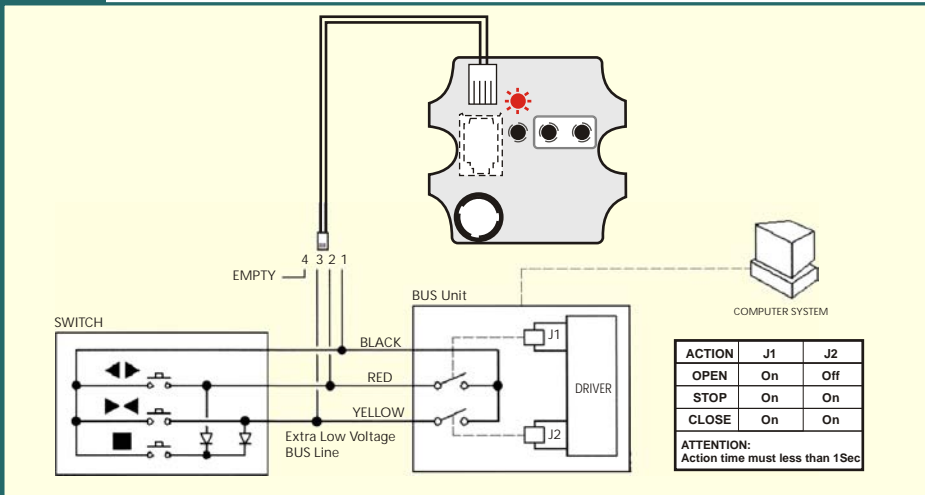

9) CONNECTING TO COMPUTING SYSTEM DIAGRAM

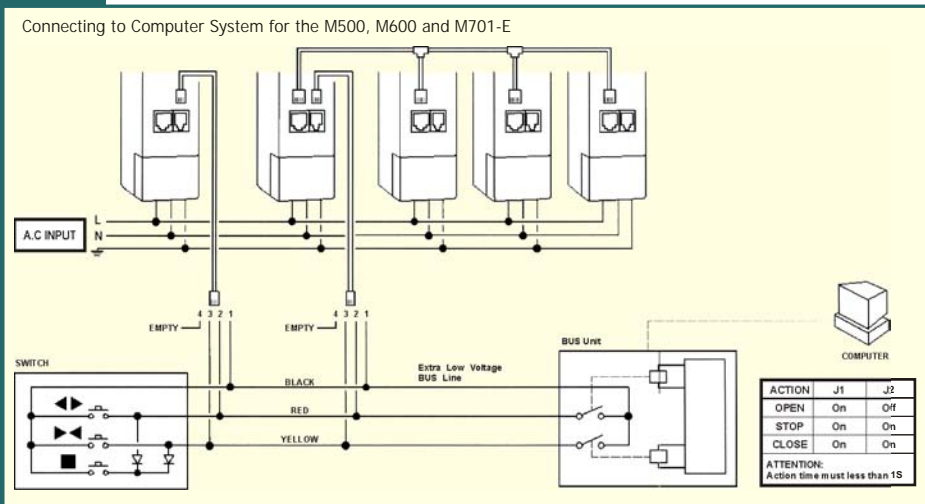

2) BUTTON FUNCTION AND INTERFACE

- 4P4C Plug: Connect out control equipment
- Cable Interface: Please refer to "System Connection"
- Indicator Light: Instruct drive working status
- Close Button: Controls drive unit to close
- Open Button: Controls drive to open
- Learning Cord Button: Please refer to Section 5 and 6 for details on this setting

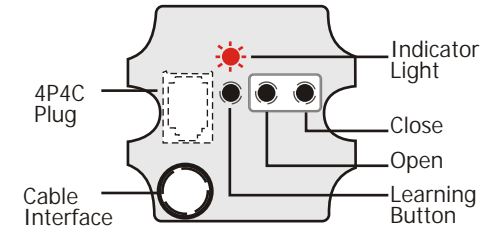

3) SYSTEM CONNECTION

POWER WIRE CONNECTION

Please connect the wire correctly according to the diagram below. Permit to parallel the wire between the motors

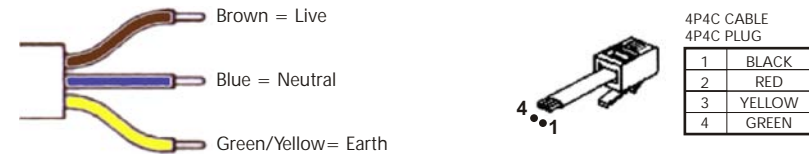

4) REMOTE INSTRUCTIONS

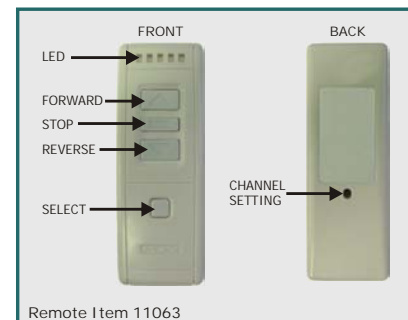

BUTTON FUNCTIONS

- (Front) UP: OPENS THE CURTAIN
- (Front) STOP: MIDWAY STOPS
- (Front) DOWN: CLOSES THE CURTAIN
- (Front) SELECT: CHOOSE CORRESPONDING CHANNEL
- (Back) CHANNEL SETTING: SETS THE REMOTE CHANNEL

5) REMOTE SETTING

Before operating the remote control, you must first set up the remote as shown in step A - "Add a New Channel". If you wish to delete all the channels, refer to step B - "Deleting Remote Channels". With regards to track assembly or installation direction, it may be necessary to change the operating direction, this can be done by following set C - "Correcting Operating Direction".

ADD A NEW CHANNEL

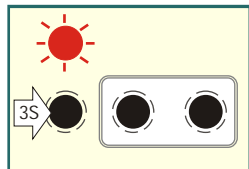

Dia 1a - Press "learning-key" for 3sec until the indicator light is on.

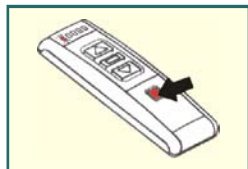

Dia 1b - Choose a channel which you want to add.



Dia 1c - Press "channel-setting" key. If operation is successful, the indicator light will flash and go off.

DELETE ALL CHANNELS

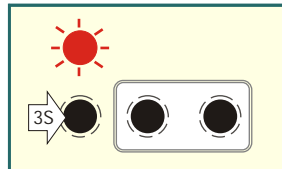

Dia 2a - Press "learning-key" for 3sec until the indicator light is on.

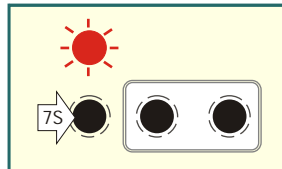

Dia 2b - Press "learning-key" again for 7sec until the indicator light flashes.

CORRECT THE DIRECTION

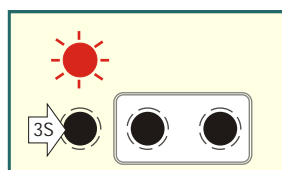

Dia 3a - Press "learning-key" for 3sec until the indicator light is on.

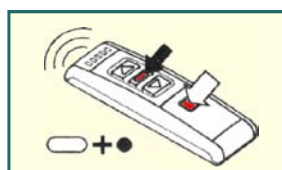

Dia 3b - Press "select", and press "stop" together.

PLEASE NOTE - When the supplied Raex remote differs from that illustrated, please refer to the remote instructions with the remote.



6) ADJUSTING LIMIT SETTINGS VIA MOTOR

The limits have not been set, please refer to 'Adjust Limit via Motor' or 'Adjust Limit via Remote'.

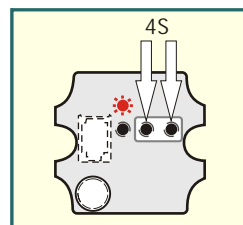

Step 1 - Press the OPEN & CLOSE at the same time for 4sec, until the indicator light is on. The motor is now at the limit setting state.

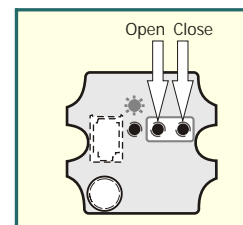

Step 2 - Press the OPEN & CLOSE buttons to make the curtain arrive at the desired point.

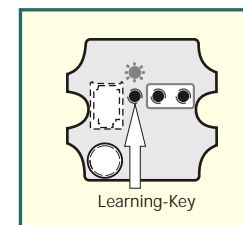

Step 3 - Press the "learning-key" to set the limit. Repeat Steps 2 and 3 if another limit setting is required.

7) ADJUSTING LIMIT SETTINGS VIA REMOTE

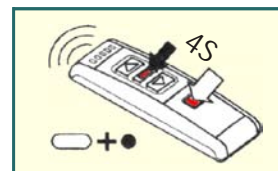

Step 1 - Press "select", and press "stop" at the same time for 4secs

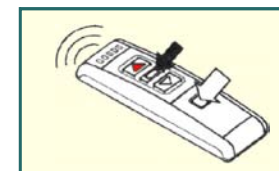

Step 1 - Press "select", and press "stop" at the same time for 4secs

